

TORQUING POWER

AP1000X Pneumatic



AP1000X--High Flow – High Speed for Heavy Duty Application

Quality Means Lower Life-Cycle Costs:

- Over 100,000 cycles.
- Continuous duty up to 122°F (50°C) ambient.
- Quiet operation (75-80 DBA @ 10,000 PSI)
- Proven Design = Proven Reliability.

Enhanced Usability:

- Cool running, continuous duty two-speed high performance pump.
- Runs on 70 cfm/90 PSI of air.
- Retract internal relief valve protects tool.
- 3-way 2-position air pilot valve standard.
- Use with single or double acting tools. Not for lifting applications.
- Standard Hand Remote.

Designed With Safety In Mind:

- Easily adjustable pressure regulator (relief) valve.
- Fixed 1,500 psi (103 bar) pressure retract relief valve.
- Rugged remote pendant to control motor and valve.
- Quick connect no-drip couplers with safety locking collar.

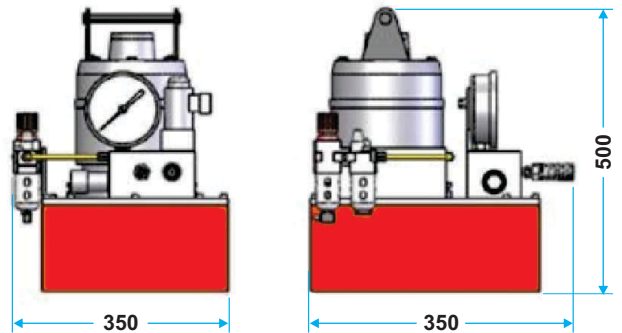

Resvr. Size (Gal.)	Valve		Motor Specifications	Flow Rate		Weight	
	Control	Type		690 psi	10,000 psi	kg	lbs
2	Pneumatic air control	3 Way/2 Pos.	6-AM-NRV; 3000 rpm; 4HP	9.4 lpm	1.1 lpm	34	75