

# TUBE BUNDLE ROLLER PBR SERIES

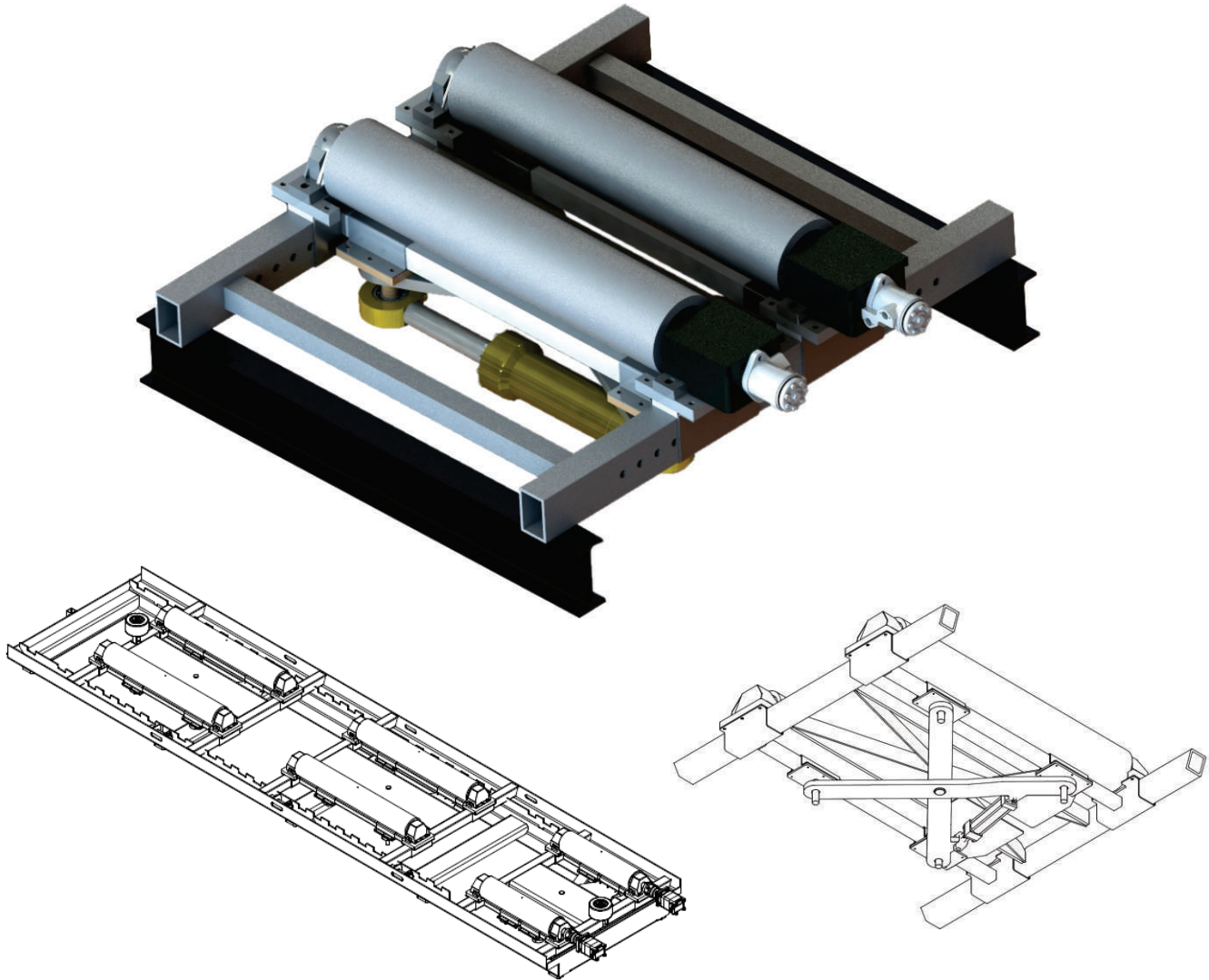

Utilizing the design and operational feedback from the industry's leading refinery, we have engineered a Tube Bundle Roller with a novel design. This roller enables the exchanger to rotate, allowing for comprehensive cleaning on the cleaning pad.

## Features :

- A new scissor-type mechanism allows for width adjustments in roller assemblies utilizing a hydraulic cylinder.
- The roller assemblies are adjustable, removable, and equipped with quick-connect fittings for hydraulic systems.
- The components are available with a standard paint finish, and optional corrosion-resistant galvanizing can be provided.
- Full-length drip pans are optional, featuring drain ports.
- The system is adjustable to accommodate bundles ranging from 8 feet to 21 feet in length and up to 6 feet in diameter.
- Included are three ratchet straps.
- Two rubber bumper wheels are positioned at the ends to ensure the bundle remains securely on the pallet.
- Motor shafts and bearings are protected by guards.
- The design incorporates a dual drive motor configuration with torque-arm mounting.
- Pillow block bearings are maintenance-free.

Model No.	Adjustable Bundles Range		Scissor Type Using	Weight	
	Length (feet)	Diameter (feet)		kg	lbs
PBR - 20H	8 to 21	2 to 6	Hydraulic Cylinder	27,216	60,000